

TRANSPORTATION HVAC



CU-32 CONDENSER



The Allied Climate Technology CU-32 Condenser is specifically designed for the transportation industry. The lightweight aluminum structure skirt mounted condenser offers enhanced performance, ease of installation and serviceability.

Features and Options

- Enhanced Copper Tube Aluminum Blue Fin Coil
- 16 Cubic Inch Filter Drier with Moisture Indicating Sight Glass
- Sealed Fan Motors
- Mounting Pattern Designed for Various Applications
- Condenser Mounted or Skirt Mounted Air Inlet Grill
- Optional High-pressure Switch

Specifications

Rating: Up to 70,000 Btu/hr

Number of Fans: 2

Fan Diameter: 12 Inch

Amperage Draw: 23 Amps @ 13.5 Volts
11 Amps @ 27 Volts

Weight: 48 Lbs.

Specifications subject to change without notice.

ALLIED CLIMATE TECHNOLOGY

715 WILLOW SPRINGS LANE

YORK, PA 17406

717-699-8800

WWW.ALLIEDCLIMATECH.COM

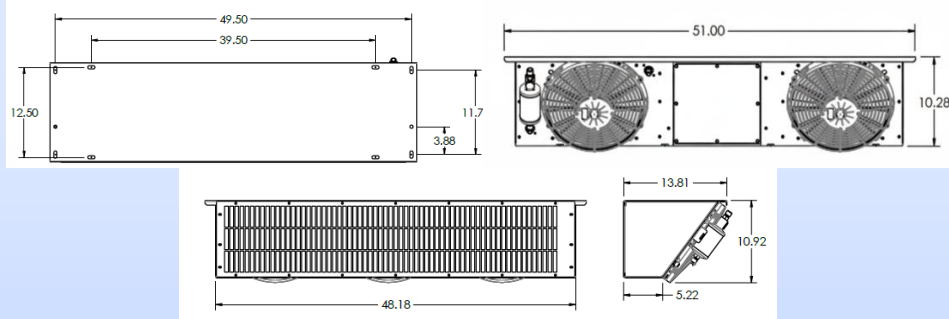

**2 YEAR
LIMITED WARRANTY**



TRUST OUR MANY YEARS EXPERIENCE IN THE TRANSPORTATION HVAC INDUSTRY TO SUPPORT YOUR REQUIREMENTS

"EXCEL THROUGH EXPERIENCE"

CU-32 Rev. 03/2026