

# TRANSPORTATION HVAC



## CU-3 CONDENSER



The Allied Climate Technology CU-3 Condenser is specifically designed for the transportation industry. The lightweight aluminum structure skirt mounted condenser offers enhanced performance, ease of installation and serviceability.

### Features and Options

- Enhanced Copper Tube Aluminum Blue Fin Coil
- 16 Cubic Inch Filter Drier with Moisture Indicating Sight Glass
- Sealed Fan Motors
- Mounting Pattern Designed for Various Applications
- Condenser Mounted or Skirt Mounted Air Inlet Grill
- Optional High-pressure Switch

### Specifications

**Rating:** Up to 82,000 Btu/hr

**Number of Fans:** 3

**Fan Diameter:** 12 Inch

**Amperage Draw:** 32 Amps @ 13.5 Volts  
16 Amps @ 27 Volts

**Weight:** 54 Lbs.

Specifications subject to change without notice.

**ALLIED CLIMATE TECHNOLOGY**

**715 WILLOW SPRINGS LANE  
YORK, PA 17406**

**717-699-8800**

[WWW.ALLIEDCLIMATECH.COM](http://WWW.ALLIEDCLIMATECH.COM)

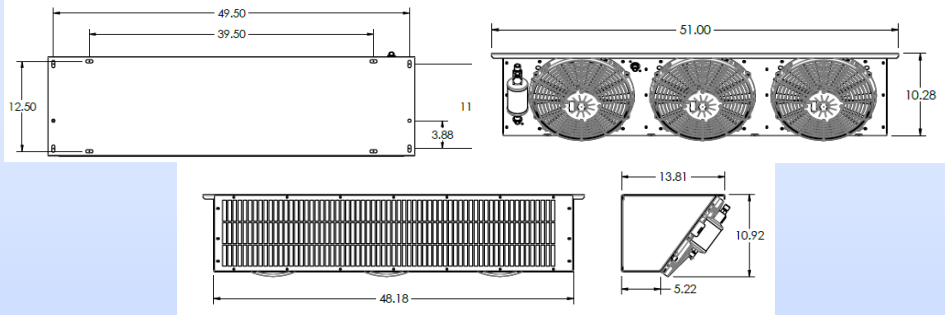

**2 YEAR  
LIMITED WARRANTY**



**TRUST OUR MANY YEARS EXPERIENCE IN THE TRANSPORTATION HVAC INDUSTRY TO SUPPORT YOUR REQUIREMENTS**

**"EXCEL THROUGH EXPERIENCE"**

CU-3 Rev. 03/2026